

## T Series



### About the product

Steelcraft T20, T18, T16, and T14 Series flush doors are designed to meet the architectural requirements for Temperature Rise rated full flush doors. Refer to the Architectural section for specifications and the selection and usage guide of the appropriate door constructions. To meet application, specification and performance requirements, the T Series door offers a wide range of specifiable options including sizes, glass light designs, optional edge constructions and hardware (mechanical, pneumatic, electrical) preparations.

T Series doors are 1 3/4" (45 mm) thick.

### Installation

1. Installation shall conform to the published Steelcraft installation instructions, ANSI A250.11-2012 (formerly SDI 105) *Recommended Erection Instructions for Steel Frames and HMMA 840*.
2. Fire Rated Assemblies must be in accordance with NFPA Pamphlet 80. The *Authority Having Jurisdiction* is the final authority on issues related to the installation and use of installed Fire Rated Doors.

### Features and benefits

Steelcraft's T Series doors offer the following standard unique features, which enhance long term performance and durability:

1. **Mineral board core** provides a 250°F (121°C) Temperature Rise rating or 450°C (232°C) at 30 minutes of test exposure, depending on hardware application.
2. **Full Height, Epoxy Filled Mechanical Interlock Edges** provide structural support and stability the full height of the door edges. Available edge options:
  - **Visible Edge Seam** (standard): full height, epoxy filled mechanical Interlocked edges with tack welds
  - **Filled Edge Seam (optional add to standard)**: seam filled with structural adhesive and dressed smooth.
  - **Welded Edge Seam (optional add to standard)**: intermittently welded using 1" long welds, then seam filled with structural adhesive and dressed smooth. Option available on T18, T16 and T14.
3. **Universal Hinge Preparations** (patented) allow for easy field conversion from standard weight .134" (3.3 mm) hinges to heavy weight .180" (4.7 mm) hinges.
4. **14 Gauge [0.067" (1.7 mm)] Inverted Top and Bottom Channels** provide stability and protection for the top and bottom edges from abuse.
5. **Beveled Hinge and Lock Edges** allow for tighter installation tolerances, ensure easier operation and eliminate binding and sticking.
6. **Recessed Designer™ Glass Trim** provides a clean, neat and flush finish with the door surface.
7. **Factory Applied Baked-On Rust Inhibiting Primer** paint in accordance with ANSI A250.10-2011.

### Specification compliance

1. Door construction for Steelcraft T Series full flush doors meets the requirements of ANSI A250.8-2014 (SDI 100).
2. Hardware preparations and reinforcements are in accordance with ANSI A250.6-2003 (R2009). Locations are in accordance with ANSI/DHI A115 unless otherwise stated.

### Fire ratings

T Series doors meet the broadest fire rating requirements. They are listed for installations requiring compliance to both neutral pressure testing (ASTM E152 and UL-10B) and positive pressure standards (UL-10C).

**Core construction**

**Standard T Series Core**

- Mineral Fiber board core
  - 250°F (121°C) Temperature Rise rating
    - single point locks
    - exit hardware
  - 450°F (218°C) Temperature Rise rating
    - single point locks
    - exit hardware
    - doors prepared for INPACT™ exit devices
    - pairs of doors with two (2) vertical rod exit devices (without astragal)
- Fire label ratings up to 3 hours
- Laminated to inside faces of both door panels with contact adhesive

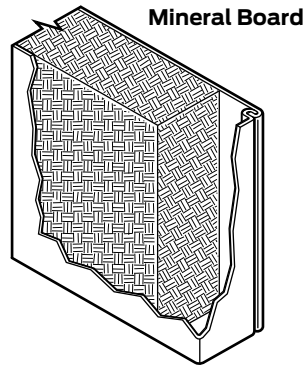

**Standard Premium Edge Construction**

- Beveled hinge & lock edges
- Full height mechanical interlock with epoxy adhesive
- Visible edge seam standard, with tack welds above and below edge cutouts for hinges, locks, etc.
- Seamless edge optional

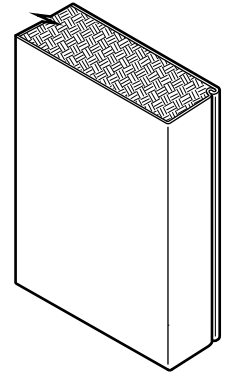

**Standard Rigid 14 Gauge End Channel Construction**

- 14 gauge inverted galvanized top & bottom channels
- Projection welded to both face sheets
- For optional caps, see ["Weather seals" on page 145.](#)

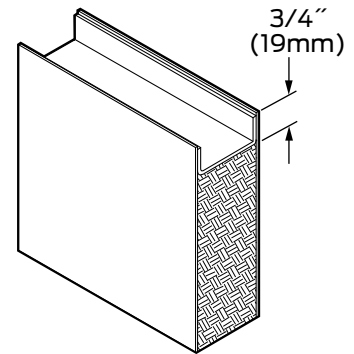

Door application and usage			
Series	Steel Thickness	Opening	Usage Frequency
T20	20 Ga (0.8 mm)	Interior: Cold Rolled Steel	Standard Duty
T20	20 Ga (0.8 mm)	Exterior: Galvanized Steel	Light Commercial applications with minimal use and abuse
T18	18 Ga (1.0 mm)	Interior: Cold Rolled Steel	Heavy Duty
T18	18 Ga (1.0 mm)	Exterior: Galvanized Steel	Heavy Commercial & Institutional applications with high use
T18	16 Ga (1.3 mm)	Interior: Cold Rolled Steel	Extra Heavy Duty
T18	16 Ga (1.3 mm)	Exterior: Galvanized Steel	Extra Heavy Commercial applications with potential of very high use
T14	14 Ga (1.7 mm)	Interior: Cold Rolled Steel	Maximum Duty
T14	14 Ga (1.7 mm)	Exterior: Galvanized Steel	Extra Heavy Commercial applications with extremely high use

### Standard hardware preparations

Typical hardware applications shown. Refer to "Hardware" section for more details.

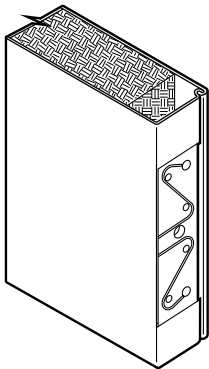

**Universal Mortise Hinge Prep**  
7 Gauge Universal hinge reinforcement

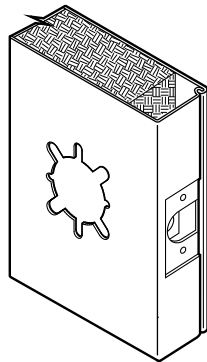

**61L Lock**

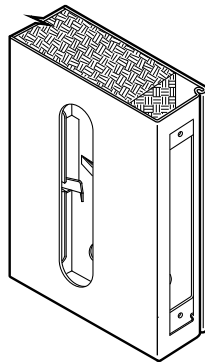

**86 Lock**

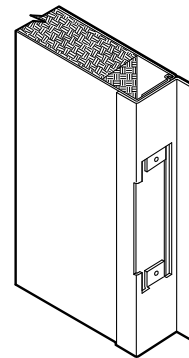

**Inactive Leaf ASA Strike Prep with Astragal attached**

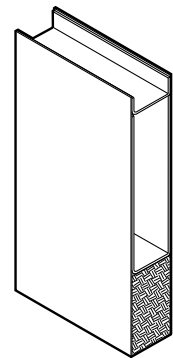

**Optional 14 Gauge Closer Reinforcement**

#### Standard: mortised and reinforced for

- Patented Universal hinge preparations allow for easy field conversion from standard 4 1/2" x .134" standard weight hinges to 4 1/2" x .180" heavy weight hinges. Optional hinge preparation for 5" x .146" standard weight hinges or for 5" x .190" heavy weight hinge are also available.
- The cylindrical 161, 61L and mortise 86 lock preps are the most commonly used active leaf preparations. The 4 7/8" (124 mm) strike prep is the most commonly used inactive leaf preparation.
- Optional reinforcements for surface and concealed Closers are available.
- Special hardware applications are available.

### Door Sizes and ANSI A250.8 Conversions

Steelcraft product selection for T Series doors has been matched to ANS/SDI Level and Model designations.

- In accordance with ANSI A250.8-2014 (SDI 100), core material is not specific to the level or model designations. Core material selection is specified based on preference and application.
- Recommended minimum frame gauge also applies to the frequency of operation of the opening.

Series	ANSI A250.8 - SDI 100			Edge Construction	Edge Maximum Sizes		Recommended Gauge of Frame
	Level	Model	Description		Single	Pair	
<b>Level 2: Heavy Duty Commercial &amp; Institutional</b>							
B18	2	1	Full Flush	Visible	4'0" x 10'0" 1219 mm x 3048 mm	8'0" x 10'0" 2438 mm x 3048 mm	16 Gauge [0.053" (1.3 mm)]
BF18		2	Seamless	Filled			
BW18		2	Seamless	Welded			
<b>Level 3: Extra Heavy Duty Commercial &amp; Institutional</b>							
B16	3	1	Full Flush	Visible	4'0" x 10'0" 1219 mm x 3048 mm	8'0" x 10'0" 2438 mm x 3048 mm	16 Gauge [0.053" (1.3 mm)] 14 Gauge [0.067" (1.7 mm)]
BF16		2	Seamless	Filled			
BW16		2	Seamless	Welded			
<b>Level 4: Maximum Duty Commercial &amp; Institutional</b>							
B14	4	1	Full Flush	Visible	4'0" x 10'0" 1219 mm x 3048 mm	8'0" x 10'0" 2438 mm x 3048 mm	14 Gauge [0.067" (1.7 mm)]
BF14		2	Seamless	Filled			
BW14		2	Seamless	Welded			

### Door edge construction

#### Optional Edge Seams available in the T Series doors:

- **TF:** the mechanical edge seam is tack welded, filled, and dressed smooth prior to applying the factory primer.
- **TW:** the mechanical edge seam is welded and dressed smooth prior to applying the factory primer.

#### Standard Visible Edge Seam

##### T Series Visible Seam Features

- Full height mechanical interlock
- Interlock is tack welded and filled with epoxy adhesive
- Visible edge seam with tack welds

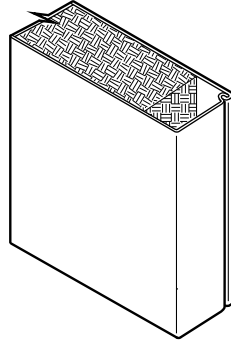

#### Optional Seamless Edge

##### TF Series Seam Filled Features

- Standard Visible Edge Seam is filled with structural adhesive and dressed smooth
- No visible edge seam

##### TW Series Seam Welded Features

- Standard Visible Edge Seam is intermittently welded using 1" long welds
- Edge Seam is then filled with structural adhesive and dressed smooth
- No visible edge seam

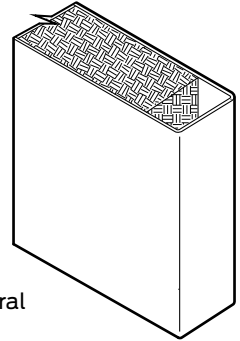

### Glass light options

(Refer to the Lights and Louvers section for further details and options – maximum 100 square inch of exposed glass)

#### Designer® Trim

- Standard for 1/4" Thick Glass
- Optional for 1/2" Thick Glass

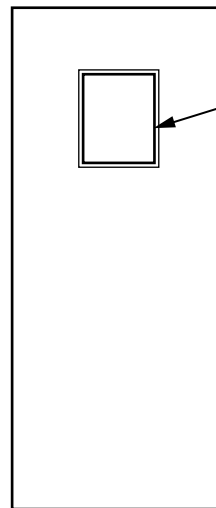
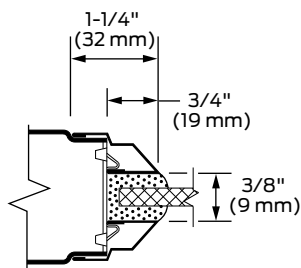

**Note:** Glazing type and thickness vary per job requirements. Max. 100 square inch exposed.